

# Gripple 45° Eyelet End Fixing

Range of hanger kits that are suitable for a variety of applications requiring bolting to brackets or fixtures.

## PRODUCT INFORMATION

- Ideal for any M6 bolt that is fixed for M&E services, such as speakers or visual display, light fittings, etc.
- For No.2, No.3 and Trapeze.
- Available in standard, 45°, 90° and large 90° versions.
- Comes as part of a ready-to-use kit, pre-cripped to the wire rope.
- Safety factor 5:1



## INSTALLATION - 45° EYELET

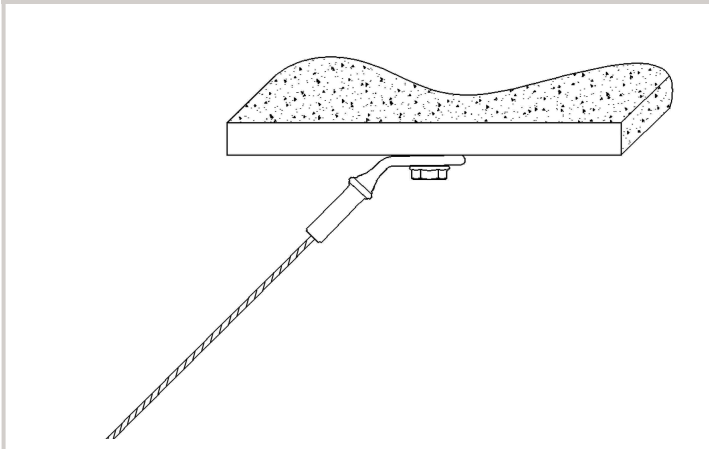

45° Eyelet under concrete

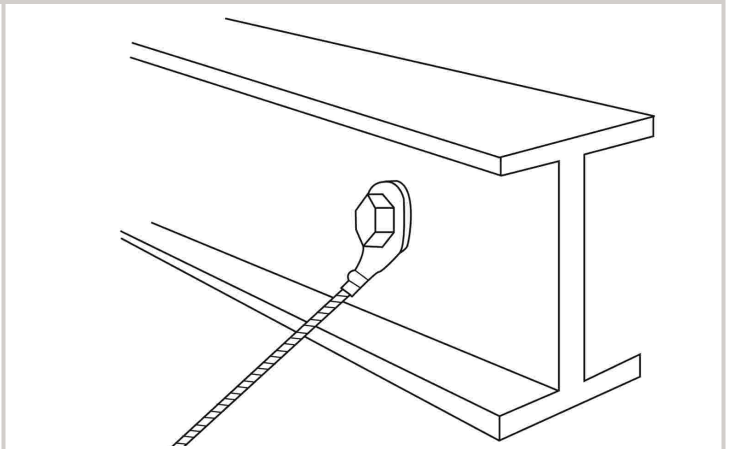

45° Eyelet on metal beam

## 45° EYELET SPECIFICATION

The Gripple 45° eyelet is made from zinc plated steel.

Size	A mm	B mm	C mm
No.2	11.2	28.7	22.5
No.3	11.2	28.7	22.5

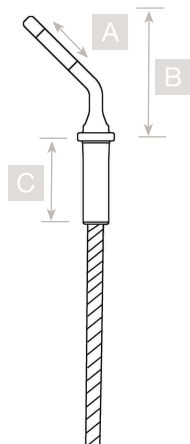

## Important Information

1. Construction materials and conditions vary on different sites. If it is suspected that the base material has insufficient strength to achieve a suitable fixing, contact Gripple Ltd. The responsibility for judgement of base material strength lies with the installer, and not with Gripple Ltd.
2. The information and recommendations given herein are believed to be correct at time of writing. The data has been obtained from tests done under laboratory, or other controlled conditions and it is the users responsibility to use the data given in light of conditions on site, taking account of the intended use of the products concerned.
3. Whilst Gripple Ltd can give general guidance and advice, the nature of Gripple products means that the ultimate responsibility for selecting the correct product for a particular application must lie with the customer.
4. All products must be used, handled and applied in accordance with current product instructions and manufacturers recommendations for use, published by Gripple Ltd.
5. Gripple's policy is one of continuous development and innovation. We therefore reserve the right to alter specifications, etc. without notice.