

Multiwedge 2 End Fixing

The Multiwedge 2 enables quick and easy suspension of building services from Ward Building Components Multideck 60 and 80 composite steel/concrete floor decking.

ADVANTAGES

- Simple, affordable alternative to the GTD clip
- Fitted easily and securely by hand, no tools required.
- Adjustable and removable, easy to reposition.
- Can be used to suspend a variety of mechanical and electrical services

PRODUCT INFORMATION

- For use in conjunction with M8 stud and M8 Flange Nut
Note that the wedge nut must be locked in place using a nut and washer, or similar locking method.
- Load rated at 90kg, 3:1 safety factor
- Sold as a kit with Gripple M8 stud hangers No.2 and No.3



INSTALLATION

1. Insert wedge nut in to channel.
2. Rotate 90° to lock in to the channel.
3. Tighten the flange nut (or nut and a washer) to the decking surface to secure the installation.

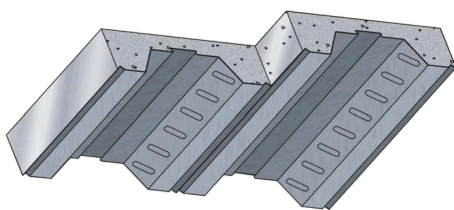
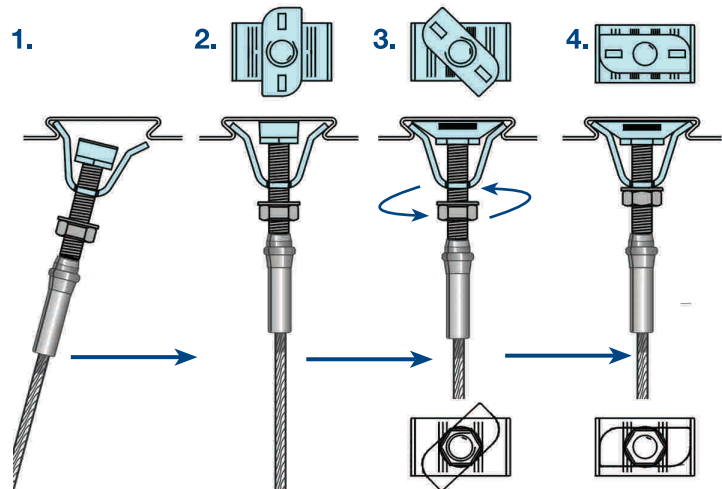

KINGSPAN



MULTIWEDGE 60
MULTIWEDGE 80

Important Information

1. Construction materials and conditions vary on different sites. If it is suspected that the base material has insufficient strength to achieve a suitable fixing, contact Gripple Ltd. The responsibility for judgement of base material strength lies with the installer, and not with Gripple Ltd.
2. The information and recommendations given herein are believed to be correct at time of writing. The data has been obtained from tests done under laboratory, or other controlled conditions and it is the users responsibility to use the data given in light of conditions on site, taking account of the intended use of the products concerned.
3. Whilst Gripple Ltd can give general guidance and advice, the nature of Gripple products means that the ultimate responsibility for selecting the correct product for a particular application must lie with the customer.
4. All products must be used, handled and applied in accordance with current product instructions and manufacturers recommendations for use, published by Gripple Ltd.
5. Gripple's policy is one of continuous development and innovation. We therefore reserve the right to alter specifications, etc. without notice.