

Purpose-made single channel, ideal for fast suspension of rectangular ducting.

ADVANTAGES

- Eliminates channel support
- Suitable for ducting made from 0.6 – 1.5 mm gauge steel
- Spreads the load across 3 fixing points, for self-drilling screws or pop rivets (not provided)
- Rubber pad prevents leakage
- Conforms to DW144 class C
- Pin allows rapid adjustment
- Load rated at 45 kg with a 5:1 safety factor
- Supplied as a ready-to-use kit



INSTALLATION GUIDELINES

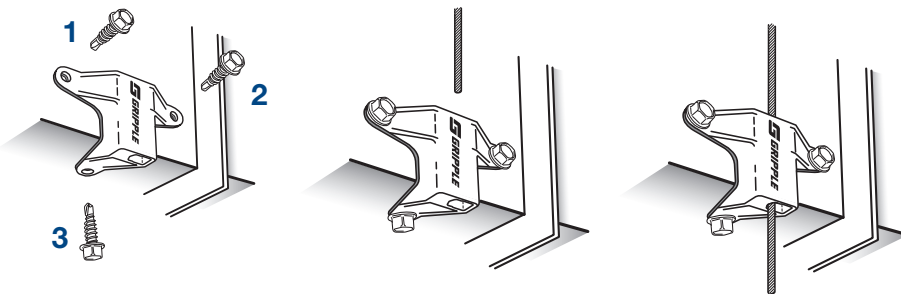

END FIXINGS



For further detailed information on any of our end fixings, please visit our website or contact us using the information below.

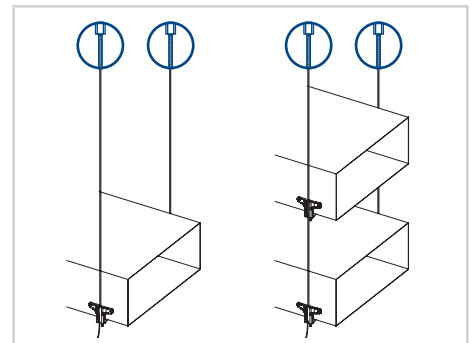

PRODUCT SPECIFICATIONS

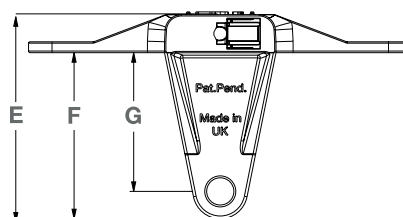
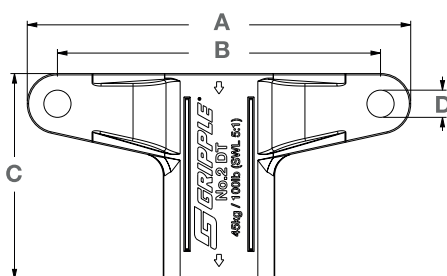

Dimension	mm
A	70.5
B	59.4
C	37.8
D	Ø - 5.0
E	38.0
F	30.5
G	25.5